

PB Series

Service Manual

LAST Rev. NO : 4

LAST Rev. Date : 2010. 02. 09

Table of Contents

1. Proper Operation / Introduction	3
1.1. Preface.....	3
1.2. Precaution.....	3
2. Classification	4
2.1. Overall View.....	4
2.2. Display Pad (Key Pad).....	4
2.2.1. PB.....	4
3. Getting Started.....	5
3.1. Sealing Method.....	5
4. Calibration Mode	6
4.1. General Calibration	6
4.1.1. C4 Setting	7
4.1.1.1. C4-1 Setting.....	7
4.1.2. SPAN Calibration Setting (C-3)	8
4.1.3. Gravity Constant Value Setting (C-9)	8
4.1.4. Calibration factor Setting (C-10).....	8
4.1.6. Percent Calibration (C-7).....	9
4.1.7. Battery Calibration (C-8)	9
5.The Schematics and Diagram	10
5.1.System Block Diagram.....	10
5.2.Circuit Diagram	11
5.2.1.Main PCB	11
5.2.2.Power PCB(Main PCB).....	12
6. Servicing & Parts Replacement	12
6.1. Trouble Shooting.....	12
6.2. Error Message.....	13
7. Options Installing.....	14
7.1. Serial Interface(Printer to Scale).....	14
7.2. Serial Interface(PC to Scale).....	14
7.3. Serial Communication Protocol.....	15
8. ROM Download Method	16
9. Exploded Views & Parts List	19
9.1. Exploded View	19
9.2. Loadcell Ass’y.....	21
9.3. Main PCB Ass’y (Top)	22
9.4. Main PCB Ass’y (Bottom).....	22
9.5. Part List.....	23

1. Proper Operation / Introduction

1.1. Preface

Thank you for purchasing of our CAS scale.

This scale has been designed with CAS reliability, under rigid quality control and with outstanding performance.

WE hope that your departments enjoy with high quality of CAS product.

This manual will help you with proper operations and care of the PB(Portable Bench).

Please keep it handy for the future references.

1.2. Precaution

- Make sure that you plug your scale into the proper power outlet.
- Place the scale on a flat and stable surface.
- Plug into a power outlet 30 minutes before operations.
- Keep the scale away from strong EMI noises may cause incorrect weight readings.
- This scale must be installed in a dry and liquid free environment.
- Do not subject the scale to sudden temperature changes.
- Do not subject the platter to sudden shocks.
- If the scale is not properly level, please adjust the 4 legs at the bottom of the scale (turn legs clockwise or counterclockwise) so as to center the bubble of the leveling gauge inside the indicated circle.

2. Classification

2.1. Overall View

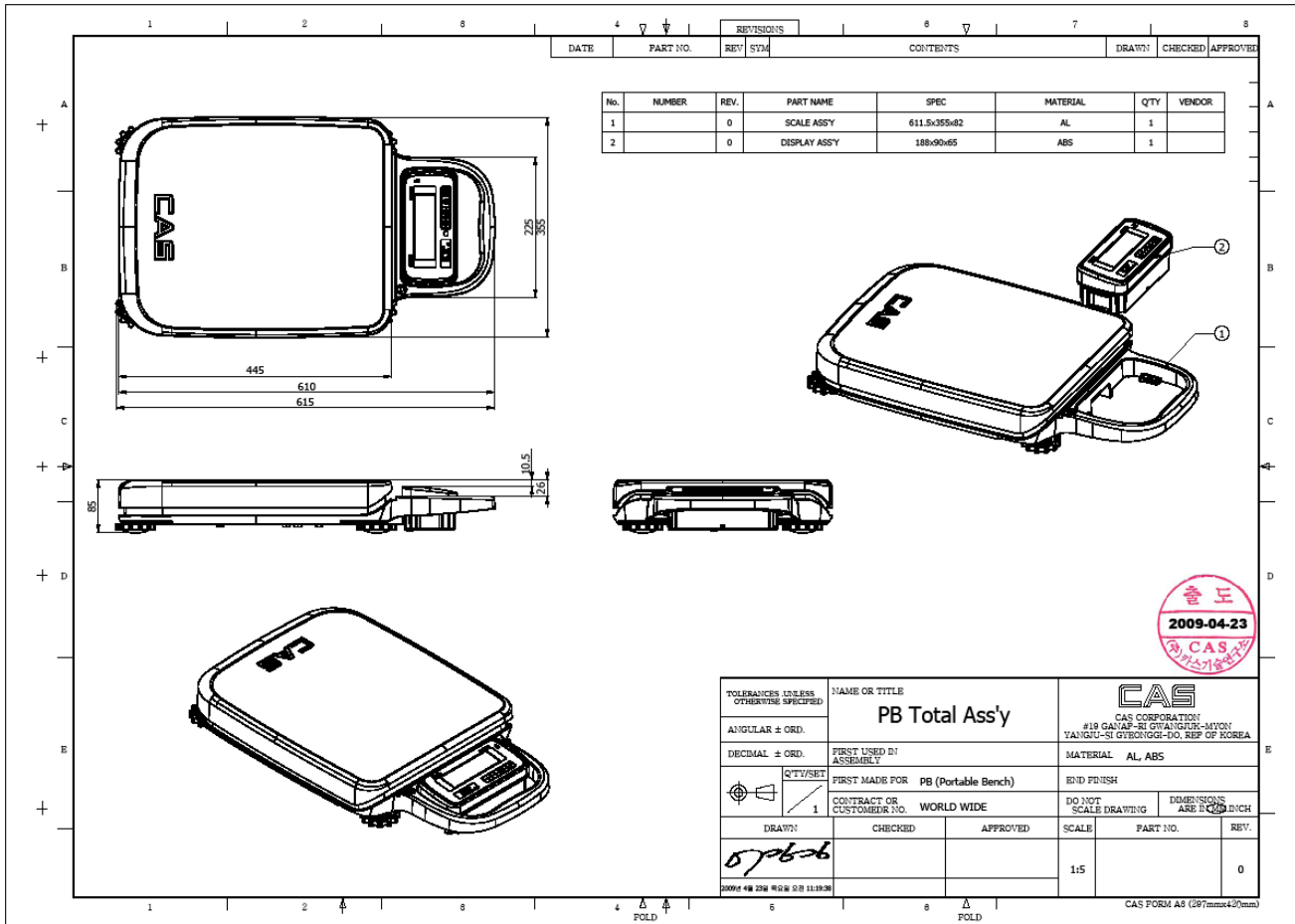

2.2. Display Pad (Key Pad)

2.2.1. PB



Key	Function
ZERO (-0-) [Set]	To set zero point To do [SET] key in the SETUP mode.
TARE	To input or cancel the tare (the weight of container).
HOLD	To make the weight of item stable. This weight is average value.
POWER	To turn on or off.

3. Getting Started

3.1. Sealing Method

< SEALING STICKER >

< SEALING BOLT >

TOLERANCES UNLESS OTHERWISE SPECIFIED		NAME OR TITLE		 CAS CORPORATION #19 GANAP-RI GWANGJU-K-MYUN YANGJU-SI GYEONGGI-DO, REP. OF KOREA	
ANGULAR ± ORD.		PB SEALING METHOD			
DECIMAL ± ORD.		FIRST USED BY ASSEMBLY		MATERIAL	
QTY/SET		FIRST MADE FOR		END FINISH	
 1		CONTRACT OR CUSTOMER NO. WORLD WIDE		DO NOT SCALE DRAWING	
		DRAWN: <i>576-6</i>		SCALE PART NO. REV.	
2009 4월 23일 목요일 08:38:33		CHECKED		APPROVED	
				1:3	
				0	

CAS FORM A8 (297mmx420mm)

4. Calibration Mode

4.1. General Calibration

Pressing and holding calibration switch press [POWER] key to go to calibration mode.

User can move to other mode by using [TARE] key or [HOLD] key in the calibration mode.

User also moves to other sub-modes for each mode by using [ZERO] key.

Please simply follow below procedure to move to other mode.

- (1) Calibration Mode: Pressing and holding “Calibration Switch” press [POWER] key.
- (2) It displays “CAL 1” after “ONE” message
- (3) Selecting menu: press [ZERO].
- (4) ENTER(Setting) : [ZERO] key

MODE	Function
CAL 1	Display normalized AD
CAL 2	Display Keypad information-
CAL 3	Weight Setting Mode “UnLoad” → [ZERO] → “MIDD” → [ZERO] after loading for 1/3 weight → “FULL” → [ZERO] after loading for Full weight → “MIDD” → [ZERO] after loading for 1/3 weight → “END”
CAL 4	Option Setting (Refer to the page 7)
CAL 5	Display filtered Raw AD
CAL 6	Function Setting (PB can't use)
CAL 7	% Calibration
CAL 8	Battery calibration
CAL 9	Gravity constant
CAL 10	Set calibration factor “Unit” → [ZERO] → select 0, 1 (0:kg, 1: lb) → [ZERO] “CAPA” → [ZERO] → select capacity → [ZERO] “MCAPA” → [ZERO] → select mid-capacity → [ZERO] “W-dP” → [ZERO] → Select Decimal Point → [ZERO] “ 1 d ” → [ZERO] → Select division → [ZERO] “Dual” → [ZERO] → Enable dual interval (0:disable, 1:enable) → [ZERO] “tare” → [ZERO] → Enable custom tare (0:disable, 1:enable) → [ZERO] →Select Tare Limit (only enable) → [ZERO]
CAL 11	Set nation(00 : OIML , 01 : NTEP , 02: KOREA)

4.1.1. C4 Setting

4.1.1.1. C4-1 Setting

BIT 6~7	Initial Zero range	11	±5%
		10	±10%
		01	±3%
		00	±2%
BIT5	Last digit enable	1	Enable
		0	Disable
BIT4	Key zero percent	1	±2% key zero percent
		0	±3% key zero percent
BIT 2~3	Successive tare	11	(+), (-) All Direction successive Tare
		10	(-) Direction successive Tare
		01	(+) Direction successive Tare
		00	One Time tare
BIT0~1	Zero mark type	10	Both(gross and net) zero indication
		01	Net zero indication
		00	Gross zero indication

Ex) BIT 0~1: 10, BIT: 2~3: 01, BIT4: 1, BIT5: 0, BIT6~7: 10

-> BIT 3\2\1\0: 0110 = 6, BIT7\6\5\4: 1001 = 9 -> 0x96 (Refer to the C4 Setting Program)

4.1.1.2. C4-3 Setting

BIT7	Dot Type	0	"." dot
		1	"," comma
BIT6	Use Preset tare (PB can't use)	0	Don't use
		1	Use
BIT5	Use Back light	0	Don't use
		1	Use
BIT4	Use Head message (PB can't use)	0	Don't use
		1	Use
BIT3	Use gram	0	Don't use
		1	Use
BIT2	Use oz	0	Don't use
		1	Use
BIT1	Use lb	0	Don't use
		1	Use
BIT0	Use Kg	0	Don't use
		1	Use

4.1.2. SPAN Calibration Setting (C-3)

- (1) Pressing and holding “Calibration Switch” press [POWER] key.
After shows “ONE” message, and then it displays “CAL 1” message.
- (2) Press [TARE] to display “CAL-3”.
- (3) Press [ZERO] key and then it displays “zero ” message.
- (4) Press [ZERO] key and then it displays “midup” message
- (5) Load middle weight (ex:1/3 full capacity) on the platform
- (6) Press [ZERO] key and then it displays “span ” message
- (7) Load full weight on the platform
- (8) Press [ZERO] key and then it displays “middn” message
- (9) Load middle weight (ex:1/3 full capacity) on the platform
- (10) Press [ZERO] key and then it display “CAL 3” message

4.1.3. Gravity Constant Value Setting (C-9)

Current gravitational Acceleration value is set to 9.7994 m/s^2 .

- (11) Pressing and holding “Calibration Switch” press [POWER] key.
After shows “ONE” message, and then it displays “CAL 1” message.
- (12) Press [TARE] to display “C-9”.
- (13) Press [ZERO] key, and then “ G-1” message and “9.7994” will be shown. The first digit, “9” will blink.
- (14) Input a gravitational acceleration value by using [HOLD] key.
- (15) Press [ZERO] key, and then “G-2” message blinks. “9.7994” will be shown. The first digit, “9” will blink.
- (16) Input a gravitational acceleration value by using [HOLD] key.
- (17) Press [ZERO] key to save the gravitational acceleration value, and “C-9 ” message will be shown.

4.1.4. Calibration factor Setting (C-10)

- (1) Pressing and holding “Calibration Switch” press [POWER] key.
- (2) After shows “ ONE” message, and then it displays “ CAL 1” message.
- (3) Press [TARE] to display “C-10”.
- (4) Press [ZERO] key, and then “UNIT ” message and “0” will be shown. The first digit, “0” will blink. It means calibration unit is “kg” (0 : kg, 1 : lb)
- (5) Input a calibration unit by using [HOLD] key.
- (6) Press [ZERO] key, and then “CAPA” message blinks. “0015” will be shown. The first digit, “0” will blink. It means a full-capability is “15 (calibration unit, kg or lb)”
- (7) Input a capability by using [HOLD] key.
- (8) Press [ZERO] key, and then “MCAPA” message blinks. “0005” will be shown. The first

digit, "0" will blink. It means a mid-capability is "05 (calibration unit, kg or lb)"

(9) Input a capability by using [HOLD] key.

(10) Press [ZERO] key, and then "W-dP " message blinks. "3" will be shown. The first digit, "3" will blink. It means a weight decimal point is "3 (will display 0.000)"

(11) Input a weight decimal point by using [HOLD] key.

(12) Press [ZERO] key, and then "1d " message blinks. "0.005" will be shown. The third digit, "0" will blink. It means a division is "0.005 (calibration unit, kg or lb)"

(13) Input a division by using [HOLD] key.

(14) Press [ZERO] key, and then "dual " message blinks. "1" will be shown. The third digit, "1" will blink. It means a dual interval is disable. (0 : disable, 1 : enable)"

(15) Input a dual interval enable by using [HOLD] key.

(16) Press [ZERO] key to save the calibration factor, and " C- 10 " message will be shown.

4.1.5. Displaying Real A/D Value (C-5)

Display Raw AD

4.1.6. Percent Calibration (C-7)

(1) Pressing and holding "Calibration Switch" press [POWER] key.

After shows "ONE" message, and then it displays "CAL 1" message.

(2) Press [TARE] to display "CAL-7".

(3) Press [ZERO] key and then it displays "per 0 " message. Select the percent value using the [numeric] key. You can choose 10~90 percent. (Last digit of percent must be 0.)

(4) Press [ZERO] key and then it displays "zero" message

(5) Press [ZERO] key and then it displays "pspan " message

(6) Load choice percentage weight of full weight on the platform

(7) Press [ZERO] key and then it displays "CAL 7" message

4.1.7. Battery Calibration (C-8)

(1) Pressing and holding "Calibration Switch" press [POWER] key.

After shows "ONE" message, and then it displays "CAL 1" message.

(2) Press [TARE] to display "CAL-8".

(3) Press [ZERO] key and then it displays voltage of battery.

(4) Change the jumper-pin of main PCB, 'BAT' to '+5V'.

(5) Press [TARE] key two times and then Press [HOLD] key two times.

And then it display '500'

(6) Change the jumper-pin of main PCB, '+5V' to 'BAT'.

(7) You can see the calibrated voltage of battery.

5.The Schematics and Diagram

5.1.System Block Diagram

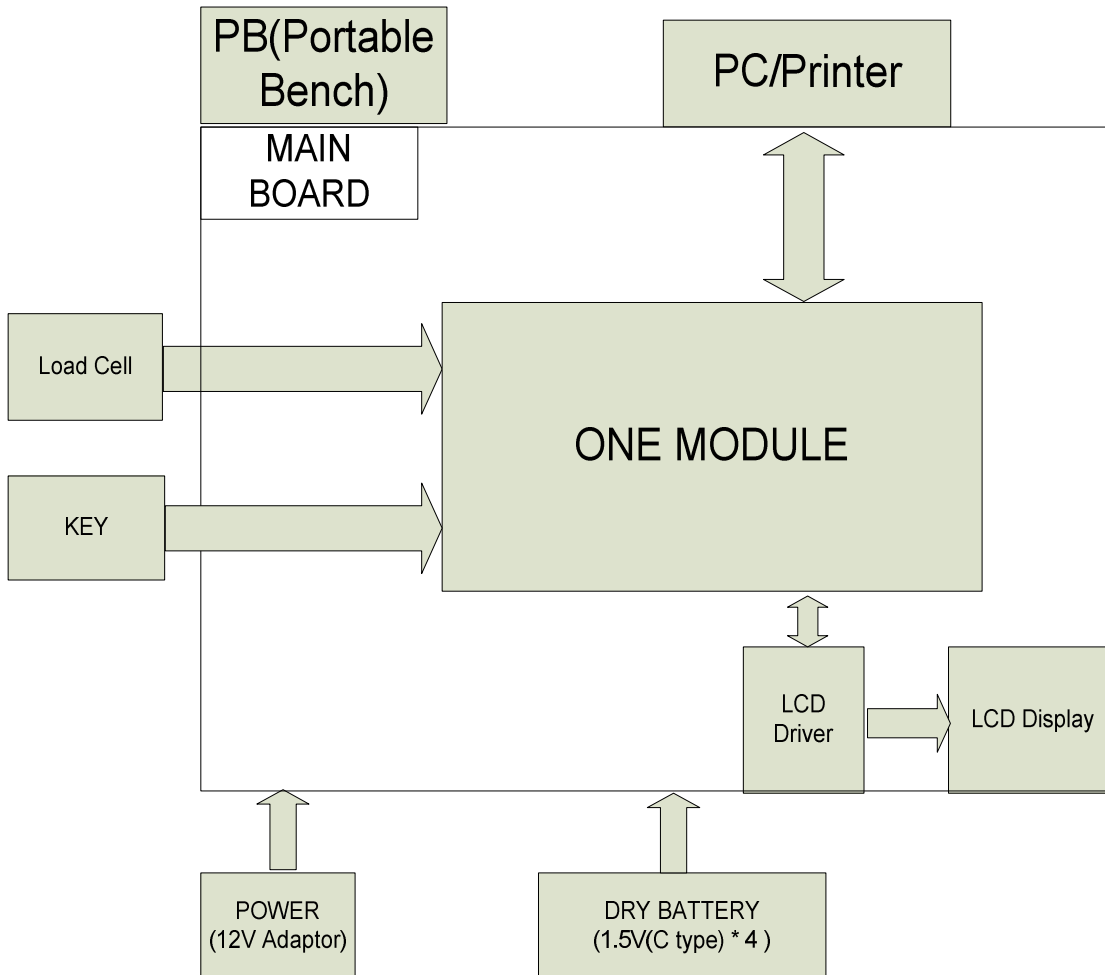

5.2.Circuit Diagram

5.2.1.Main PCB

MODULE CONNECTOR PART

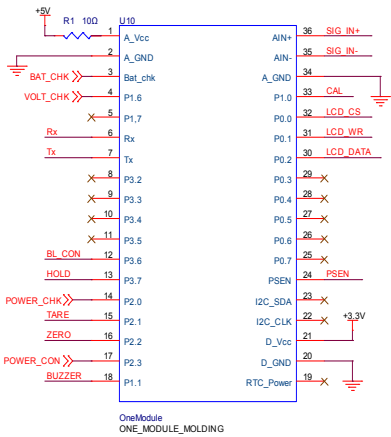

LOADCELL PART

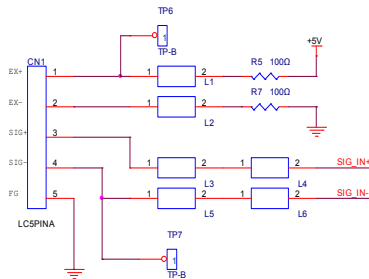

DISPLAY & BACK LIGHT PART

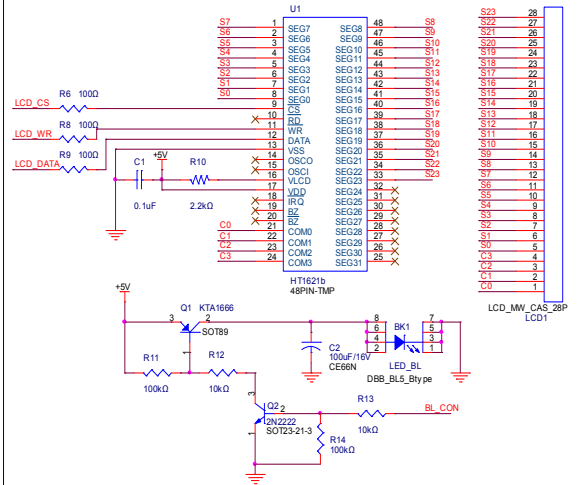

PROGRAM PART

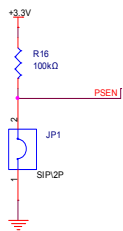

CAL PART

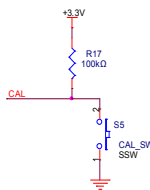

KEY & BUZZER PART

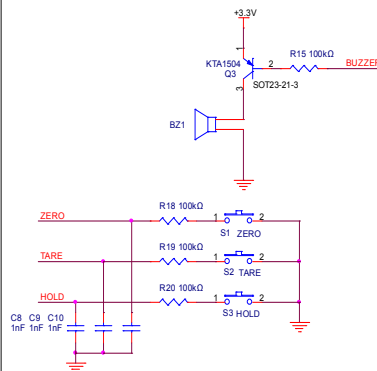

RS232 CONNECTOR PART

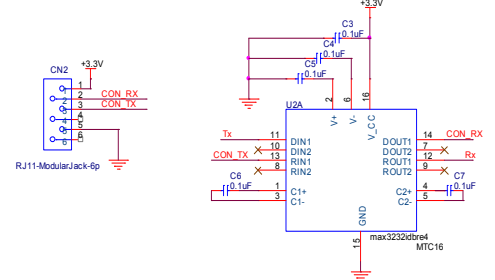

Title		
PB-LCD MAIN CIRCUIT		
Size	Document Number	Rev
B	6100-PPB-0000-0	0.3
Date	Monday, December 22, 2008	Sheet 1 of 2

5.2.2. Power PCB(Main PCB)

RECHARGEABLE BATTERY

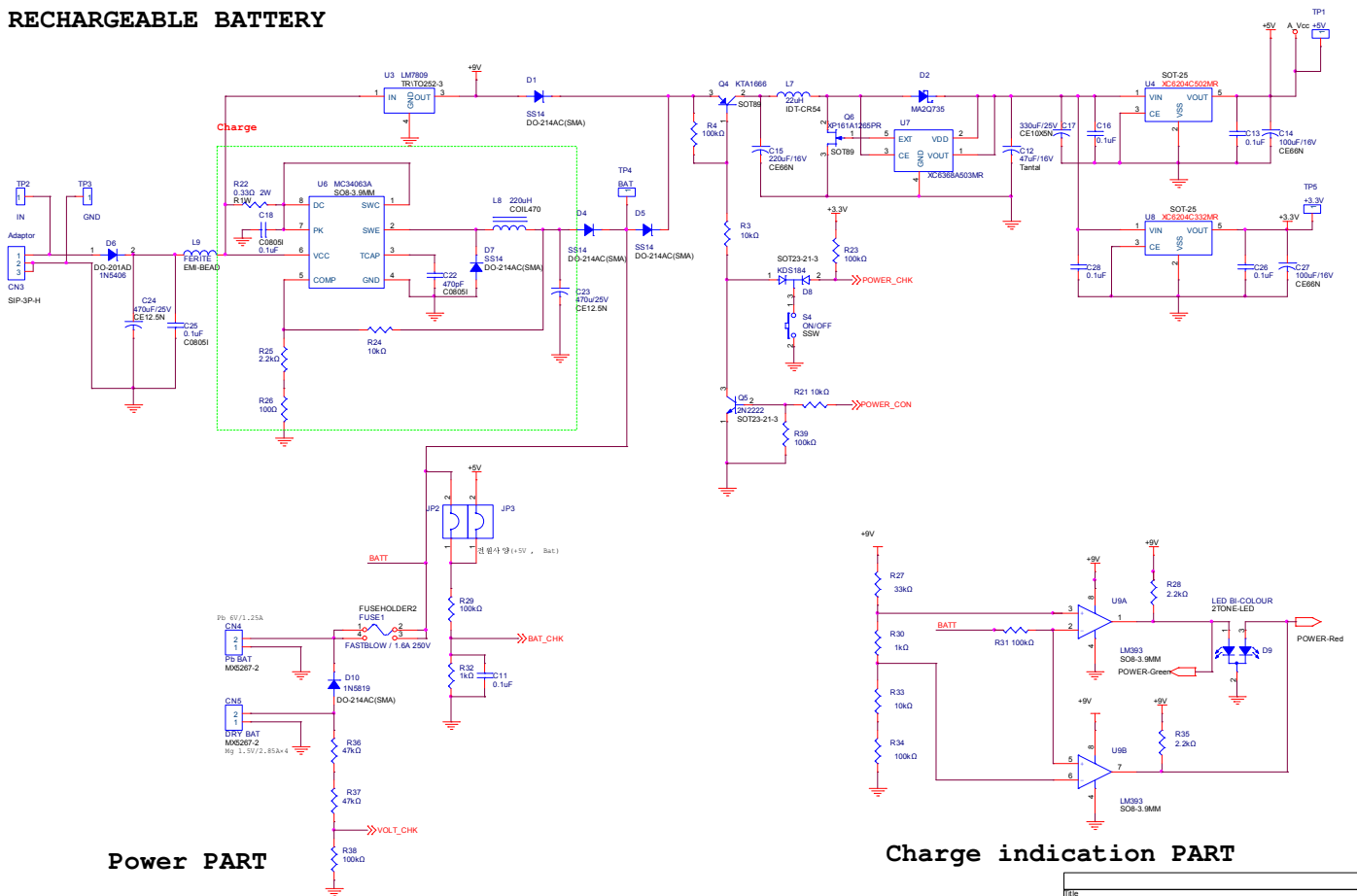

Power PART

Charge indication PART

PB LCD POWER CIRCUIT DIAGRAM		
Size	Document Number	Rev
A3	6100-PPB-0000-0	0.3
Date:	Monday, December 22, 2008	Sheet 2 of 2

6. Servicing & Parts Replacement

6.1. Trouble Shooting

SYMPTOM	PROBABLE CAUSE	REMEDY
ERROR 0 (unstable error)	1)The Scale is not put on the flat part. 2)A Vibration or wind is exist around The Scale.	- Check a foot. (Footh are must all touched in flat part.) -Check a PCB's field ground. (Field ground is must connected to platform.) - Move the scale to the stable place.
ERROR 1(initial zero)	1)The Scale is not operate Calibration 2)Cable is not connected between Loadcell and PCB.	-Operate Calibration. -Check a L/C and PCB. (L/C and PCB are must connected.)

Service Manual – PB Series REV NO : 4

Batt -> Error 0	<p>1)ONEMODULE(A/D Converter) is damaged.</p> <p>2)The Scale is not operate Battery Calibration</p>	<p>-Check a battery voltage(C-8) and then operate a battery calibration.</p> <p>-Check the A/D value. (C-1) If place a weight, A/D value have to changed.</p>
NOT OPERATION(POWER OFF)	<p>1)Power ON/OFF Key is damaged.</p> <p>2) Battery discharge or not connected.</p> <p>3)Fuse is down.(Open)</p> <p>4)Power cable is down.</p>	<p>-Check a output voltage, holding a Tact S/W.</p> <p>-Check a battery connection and Battery voltage.</p> <p>-Check a fuse connection</p>

6.2. Error Message

ERROR LIST	REASONS	SOLUTION
"Err 0"	The "Err 0" occurs when scale is not stable.	Remove unstable facts.
"Err 1"	The "Err 1" occurs when a current zero point has shifted from the last span calibration.	Please call your CAS dealer.
"Err 2"	The "Err 2" is not a real error. Only it prompts return CAL switch to the normal position.	Please call your CAS dealer.
"Err 3"	The "Err 3" is an overload error.	Please remove the weight.
"Err 9"	The "Err 9" is no weight error. When scale set counting number in counting mode, you must load the weight If you have no weight on your scale, you can see this error message.	Please load the weight on your tray.
"Err 11"	The "Err 11" means a writing error of the internal nonvolatile memory. To recognize this error, be sure to check the voltage on the circuit and do calibration procedures.	If it still has "Err 11", replace the digital module.
"Err 12"	The "Err 12" warns that the scale has lost the parameters for weighing regulations or has lost the factors for a digital span calculation.	Enter each condition codes again. Please try a span calibration again if still not fixed.
"Err 14"	The "Err 14" means calibration range is not correct.	Please call your CAS dealer.

7. Options Installing

7.1. Serial Interface(Printer to Scale)

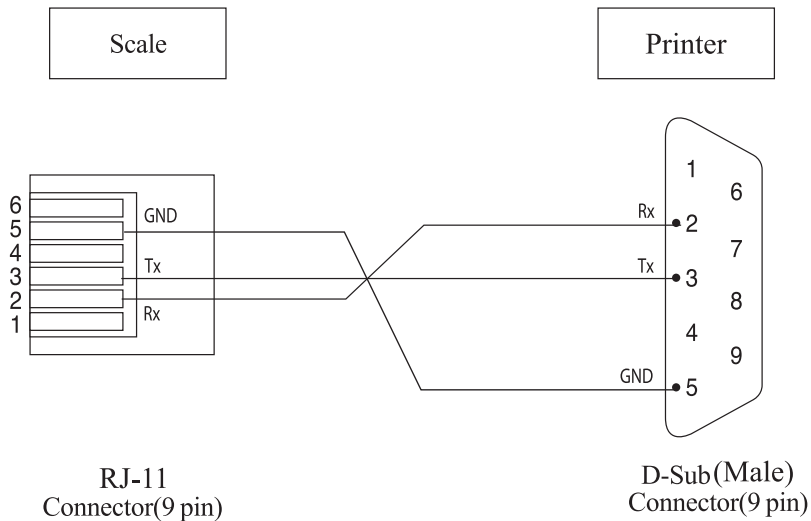

7.2. Serial Interface(PC to Scale)

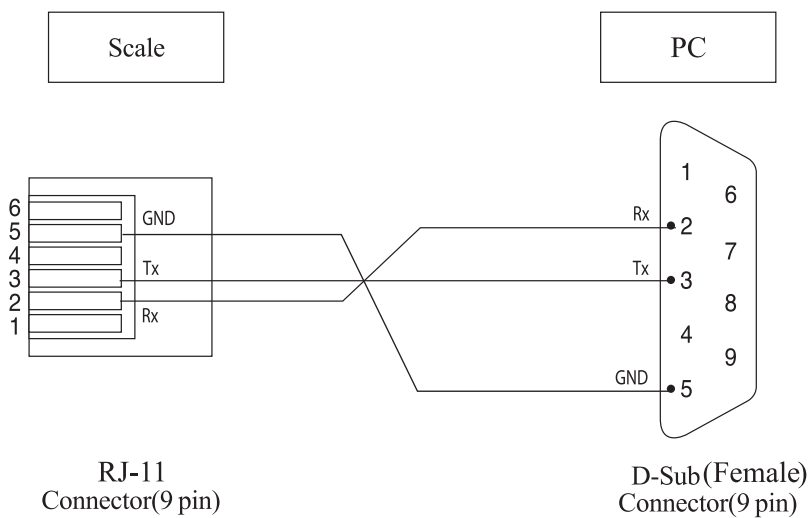

- ➔ 8-BIT ASCII code
- ➔ None parity
- ➔ 1 stop bit
- ➔ baud rate 9600

7.3. Serial Communication Protocol

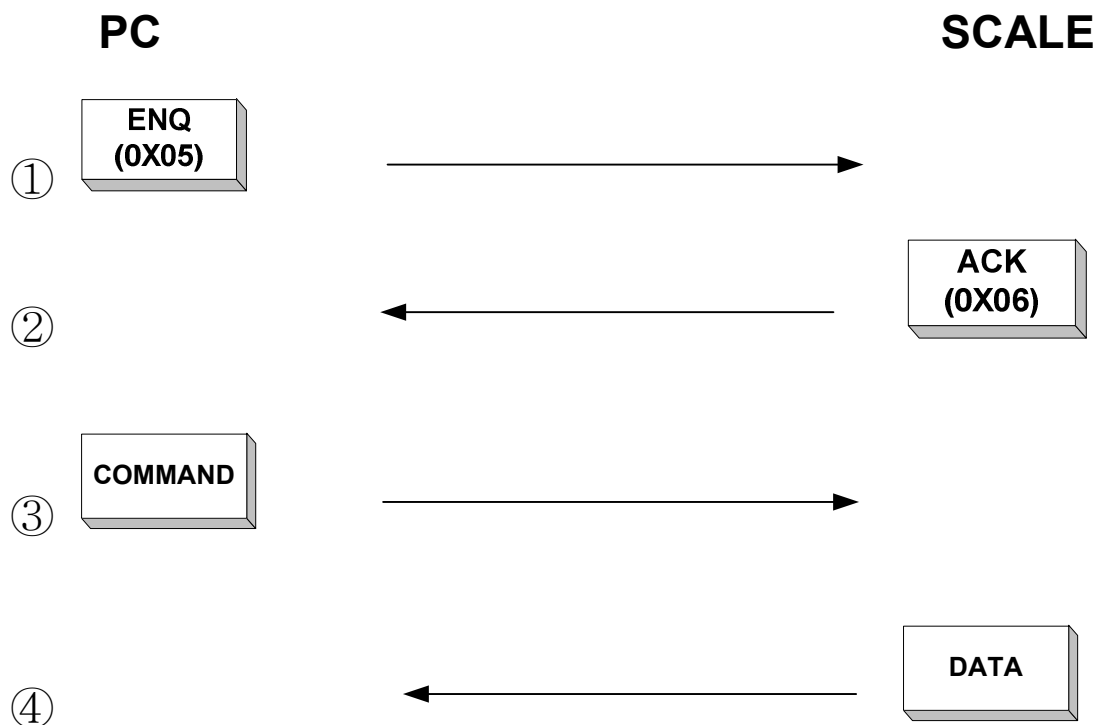

7.3.1. Transmission Data description

DATA	Value(HEX)	Description
SOH	01h	Start of heading
STX	02h	Start of text
STA	S(53h),U(55h)	S: Stable , U:Unstable
SIGN	-(2Dh),SP(20h)	Sign of the weight data
W5~W0		Weight data
P7~P0		Total price data
U7~P0		Unit price data
PN4~PN0		PLU Number data
UN1,UN2	KG,LB	Unit of Weight
BCC		Block check character exclusive or(^)
ETX	03h	End of text
EOT	04h	End of transmission

7.3.2. COMMAND (DC1) & Data Format

※ COMMAND : DC1(0X11) SCALE->PC DATA FORMAT

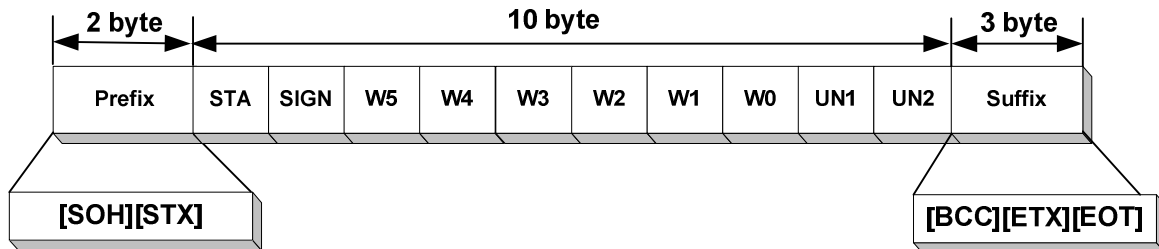

Weight Value Data Format

8. ROM Download Method

(1) Connect a RS-232C Cable, between the scale and PC and then excute a O/M Downloader program.

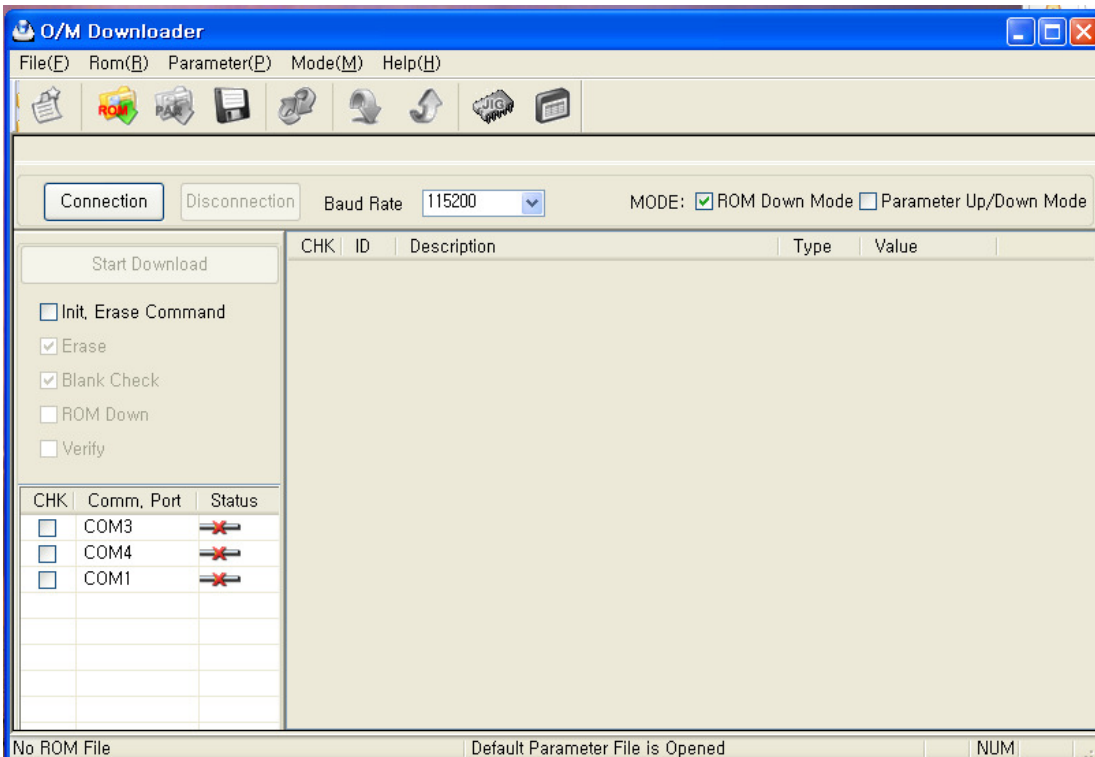

Service Manual – PB Series REV NO : 4

(2) Check a 'Communication port' and click the 'Init. Erase Command'. And then Click the 'Start Download', Communication port will be "Ready" status.

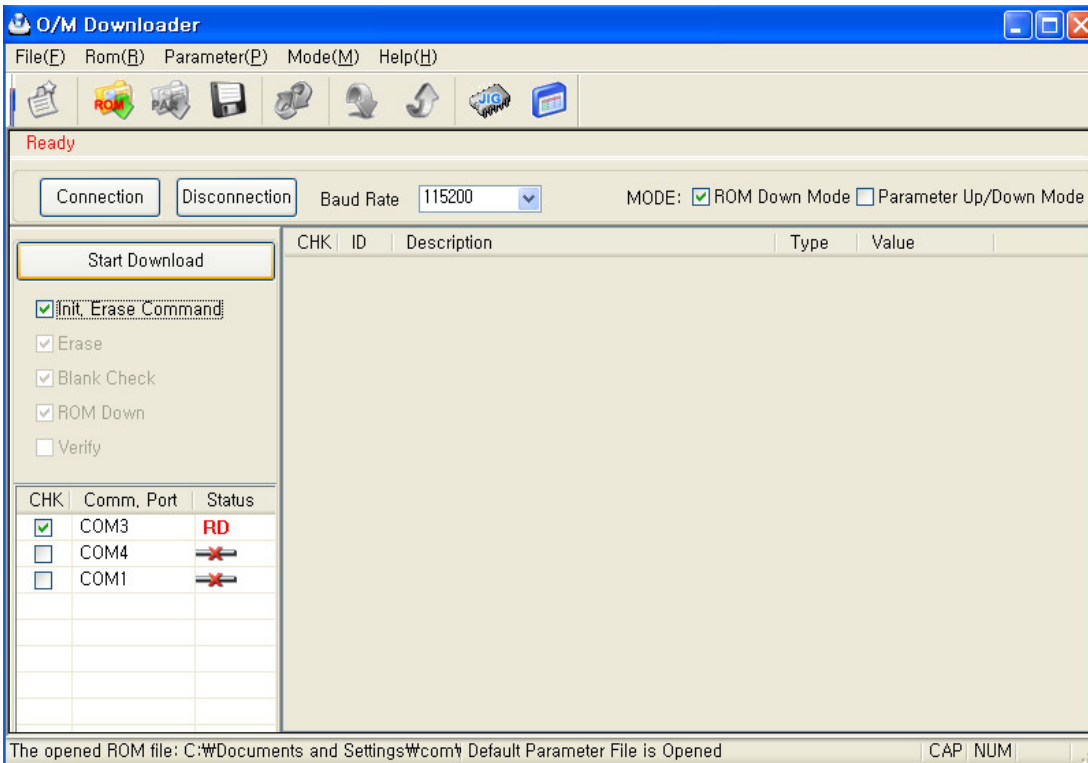

(3) Push a 'Open ROM File' button and then open the ROM File.

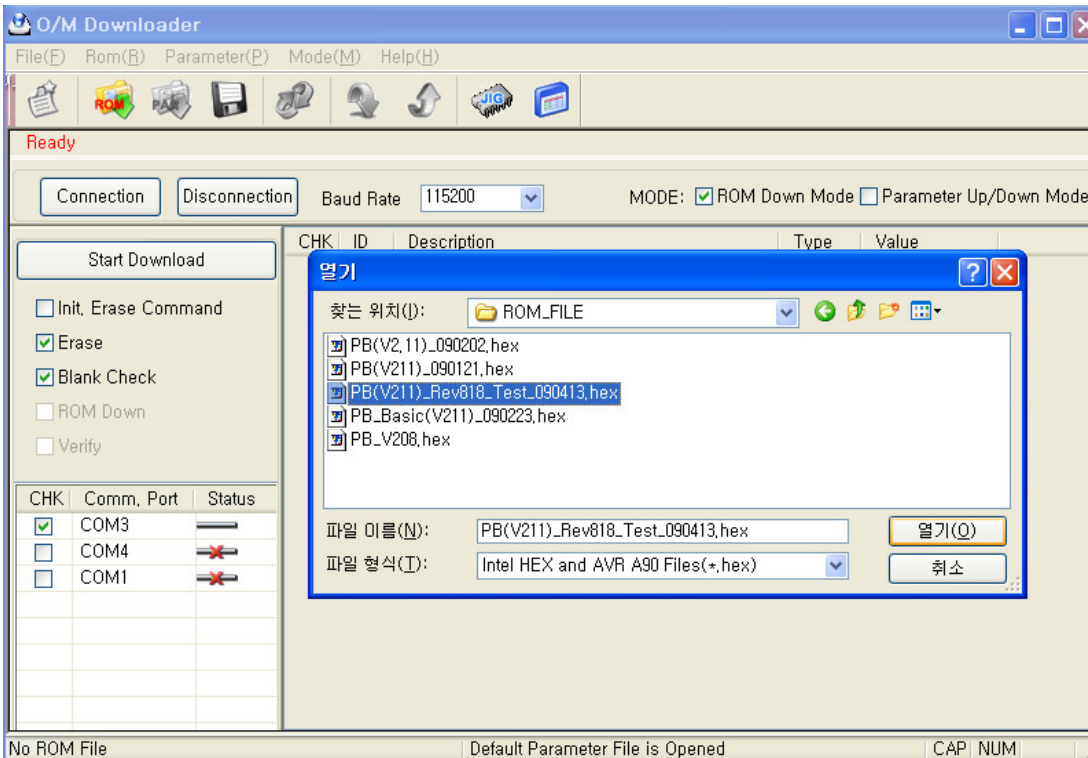

Service Manual – PB Series REV NO : 4

(4) If click the ‘Start Download’ holding a power ON/OFF key, You will see ROM Downloading display and then ROM download will be finished.

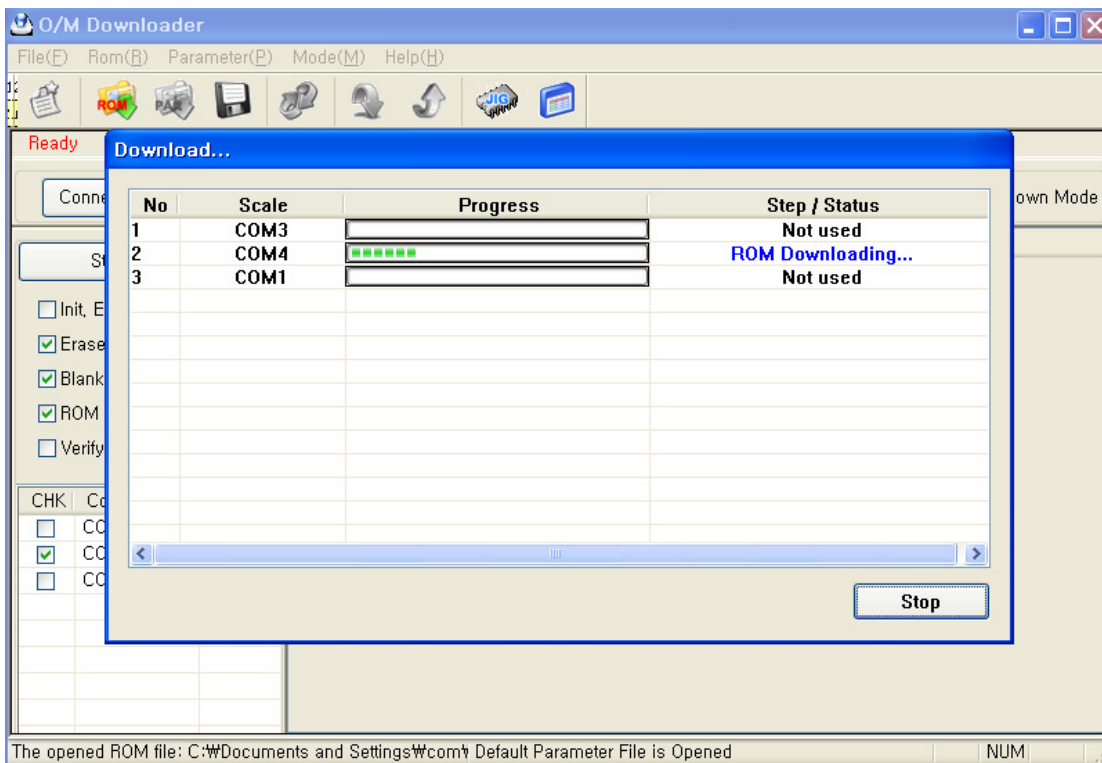

9. Exploded Views & Parts List

9.1. Exploded View

9.1.1. Display Ass'y

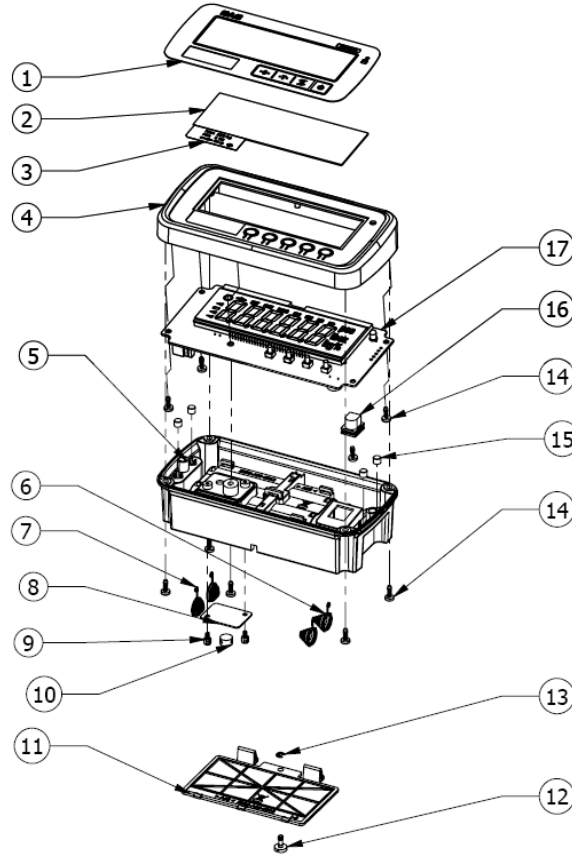

No.	NUMBER	REV.	PART NAME	SPEC	MATERIAL	Q'TY	VENDOR
1	2200-A00-0003	0	KEY BOARD PAD	167*79*0.2t	PC 0.2t	1	
2	2010-A00-0034	0	DISPLAY FILTER	135.5*46.5*1t	투명 PC 1t	1	
3	9020-A00-0078	0	CAPA STICKER	46.7x16.6x0.1t		1	
4	2000-A00-0311	0	DISPLAY UPPER	188*90*26.5	ABS 780 (KUMHO)	1	
5	2000-A00-0312	0	DISPLAY LOWER	188*90	ABS 780(KUMHO)	1	
6	1590-A00-0043	0	BATTERY SPRING A	ø1*20*21	SWC	2	
7	1590-A00-0044	0	BATTERY SPRING B	ø1*20*21	SWC	2	
8	1030-A00-0203	0	SEALING PLATE	35.2*26*1t	SPC	1	
9	1265-A00-0001	0	BOLT-SEALING	M3*5 (황동) BI	황동	2	
10	9900-A00-0001	0	봉인납	수출용	pb	1	
11	2000-A00-0313	0	BATTERY COVER	111.3*63.8*14.5	ABS 780(KUMHO)	1	
12	1261-A00-0004	0	BATTERY COVER BOLT	M4*0.7*8.5(SUS)TP	SUS	1	
13	1561-MSU-0300	0	E-RING	Φ3*Φ7*0.6	SUS	1	
14	1512-MSU-0410	0	SCREW TAPPING (PH)-2	M4*10	SUS	9	
15	1070-A00-0005	0	MAGNET	ø6*5(N30)	MAGNET	4	지구마그넷
16	7840-W00-0303	C	CONNECTOR WIRE	3P*220*303(CORE)		1	
17		0	MAIN PCB ASS'Y			1	

9.1.2. Scale Ass'y

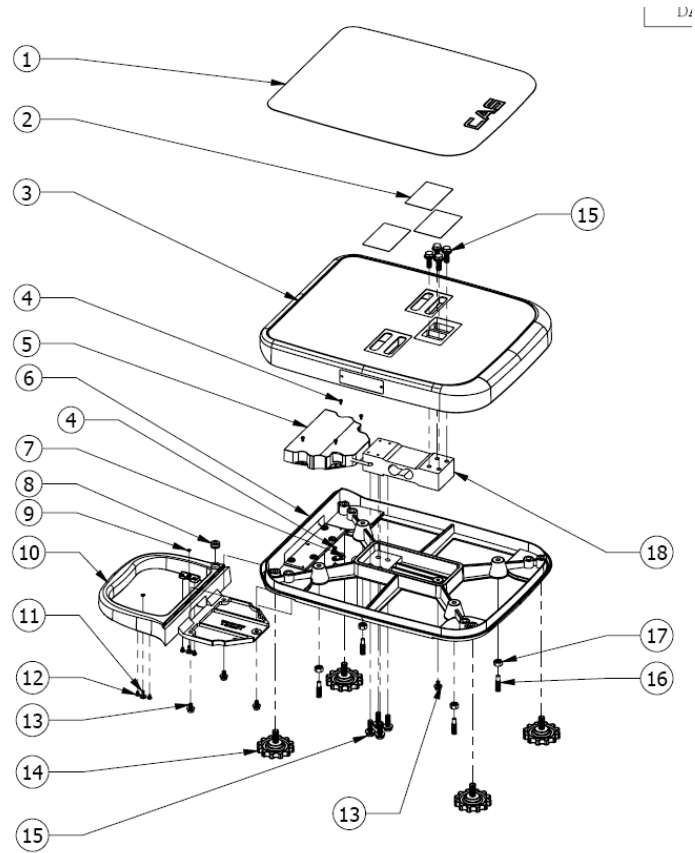

No.	Number	Rev	Description	SPEC	MATERIAL	Q'TY	REMARK
1	2008-A00-0004	0	UPPER PAD	400*328*0.5t	PVC 0.5T	1	
2	2008-A00-0005	0	PVC SHEET	83x53x0.5t	PVC SHEET 0.5t	3	
3	1100-A00-0089	0	UPPER PLATFORM	443*355*45	AA 380-F DIE	1	
4	1502-A00-0306	0	SCREW MACHINE(PH)	M3*6	SCM	5	
5	2000-A00-0314	0	WIRE COVER	156*115*26.5	ABS 780(KUMHO)	1	
6	1100-A00-0090	0	LOWER BODY	610*355*49.5	AA380F-DIE	1	
7	7642-S00-0003		CABLE CLAMP	DA-3N	ABS	1	
8	2022-A00-0004	1	WATER LEVEL GAGE	φ14.9*8(S-2000)	ABS	1	
9	1561-MSU-0300	0	E-RING	Φ3*Φ7*0.6	SUS	2	
10	1100-A00-0091	0	BRACKET HANDLE	295*248*49.5	AA 380-F DIE	1	
11	1261-A00-0004	0	BATTERY COVER BOLT	M4*0.7*8.5(SUS)TP	SUS	2	
12	1502-A00-0405	0	SCREW MACHINE(PH)	M4*5	SCM	4	
13	1521-A00-0610	0	BOLT HEXAGON(WA)	M6*12(8.8T)	SCM	4	
14	2610-A00-0015	0	FOOT	M10*1.5*@70	RUBBER(NBR)	4	
15	1521-A00-0825	0	BOLT HEXAGON(WA)	M8*25(8.8T)	SCM	8	
16	1535-MSU-0830	0	BOLT-WRENCH(ST)	M8*30-SUS	SUS	4	
17	1540-MSU-0800	0	NUT	M8*1.25	SUS	4	
18			LOADCELL	BCS	AL-2024	1	

9.2. Loadcell Ass'y

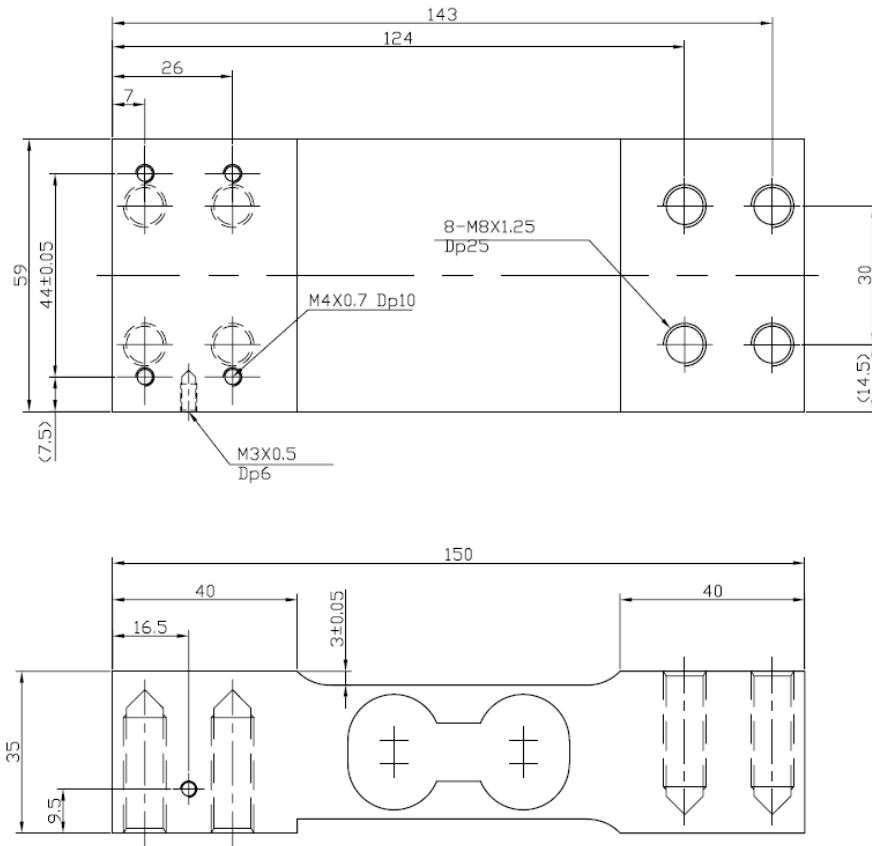

Specifications

Capacity	50, 100, 250 Kgf
Rated Output	2.0±0.2mV/V
Zero balance	0±0.1mV/V
Accuracy class	
Combined error	0.03%
Repeatability	0.01%
Creep for 30min.	0.03%
Temperature effect on	
Zero value	0.028%/10°C
Span value	0.015%/10°C
Excitation voltage	
Recommended	10V DC
Maximum	15V DC
Resistance	
Input	1100±100Ω
Output	1000±10Ω
Insulation	>2000MΩ
Compensated temperature range	-10°C~40°C
Operating temperature range	-20°C~70°C

9.3. Main PCB Ass'y (Top)

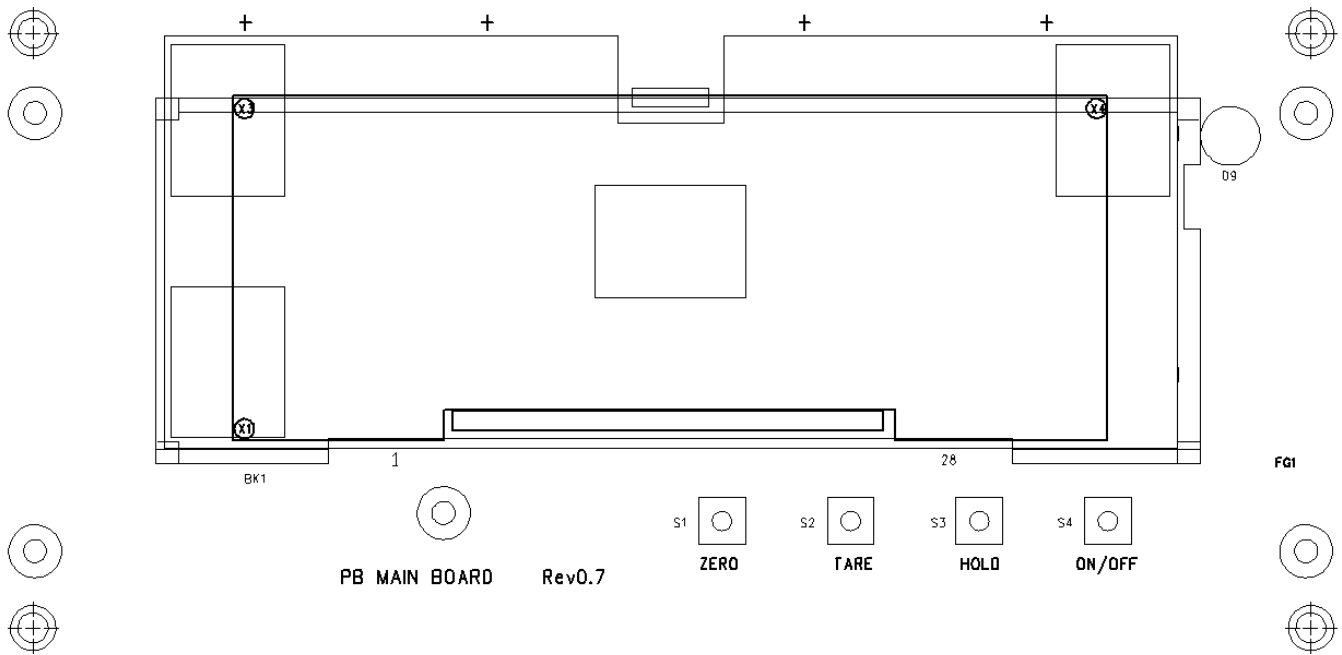

9.4. Main PCB Ass'y (Bottom)

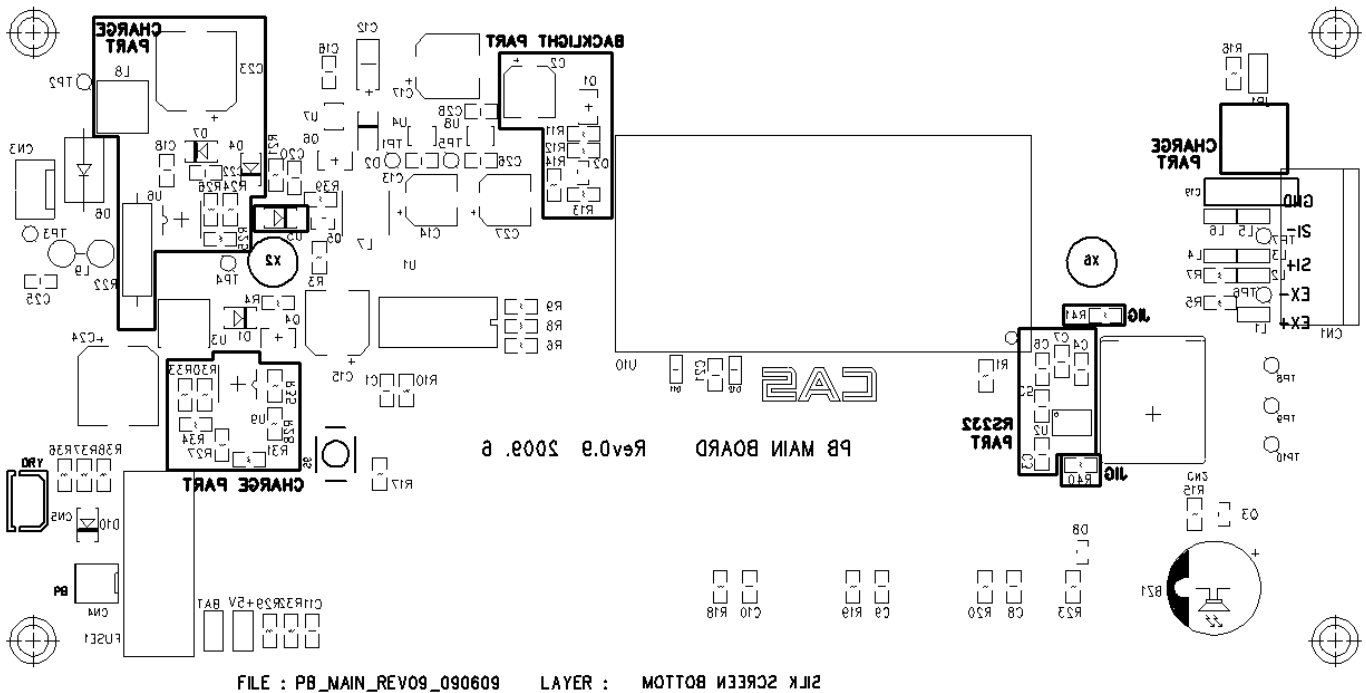

9.5. Part List

1.1 MAIN PCB ASS'Y						
No	Part Name	Specification	Part Number	Q'ty	Remark	구분
1	PCB-MAIN	6100-PPB-0000-0(PB,LCD)	6100PPB00000	1		신규
2	ONE MODULE	ONE MODULE	6PA0A0000000	1	U10	
3	IC(REGULATOR)	XC6204C502MR(5.0V)	6220IS0C5020	1	U4	
4	IC(REGULATOR)	XC6204C332MR(3.3V)	6220IS0C3320	1	U8	
5	IC(LCD DRIVER)	HOLTEX HT1621B	6224I0016210	1	U1	
6	IC(DC DC CONVERTER)	XC6368A553MR	6242IS063680	1	U7	신규
7	TRANSISTOR CHIP	KTA1504 SY	6281I0015040	1	Q3	
8	TRANSISTOR CHIP	KTA1666	6281I0016660	2	Q1,4	
9	TRANSISTOR CHIP	2N2222AS	6281I0022220	2	Q2,5	
10	IC(REGULATOR)	KA7809A(D-PACK)	6220IS078090	1	U3	
11	MOSFET(N-CH) CHIP	XP161A1265PR	6273I0012650	1	Q6	신규
12	DIODE POWER	1N5819(SMD)	6291IS058190	2	D1,10	
13	DIODE-POWER	1N5406	6291IP054060	1	D6	
14	DIODE-CHIP	KDS184	6294ICP01840	1	D8	
15	DIODE-CHIP	MA2Q735	6293ISK07350	1	D2	신규
16	RESISTOR-CHIP 1/10W	WR06X0000JT(0Ω)	6527ID00000A	1	D5	Only Basic
17	RESISTOR-CHIP 1/10W	RR1220P-000D(0Ω)	6527ID000000	4	R5,7,40,41	Only Basic
18	RESISTOR-CHIP 1/10W	RR1220P-100D(10Ω)	6527ID001000	1	R1	
19	RESISTOR-CHIP 1/10W	RR1220P-101D(100Ω)	6527ID010000	6	R6,8,9,18,19,20	
20	RESISTOR-CHIP 1/10W	RR1220P-102D(1KΩ)	6527ID300100	3	R3,10,32	
21	RESISTOR-CHIP 1/10W	RR1220P-103D(10KΩ)	6527ID301000	6	R4,13,15,21,36,37	
22	RESISTOR-CHIP 1/10W	RR1220P-103D(30KΩ)	6527ID303000	1	R12	
23	RESISTOR-CHIP 1/10W	RR1220P-104D(100KΩ)	6527ID310000	7	R11,14,16,17,23,29,39	
24	RESISTOR-CHIP 1/10W	RR1220P-123D(12KΩ)	6527ID301200	1	R38	
25	INDUCTANCE	HB-1M2012-102JT(TP2,LP2,DBB)	6670T0001020	6	L1,2,3,4,5,6	
26	INDUCTANCE	CR-54(22uH)	6670T0200220	1	L7	신규
27	EMI BEAD FILTER	BFD-3565 R2	6800F003565A	1	L9	
28	CONDENSER-CHIP	CL21B 102KBNC	6712CHP01020	3	C8,9,10	
29	CONDENSER-CHIP	100uF/16V(SMD)	6706C1601000	3	C2,14,27	
30	CONDENSER	330uF/25V(SMD)	6706C2503300	1	C17	신규
31	CONDENSER	220uF/25V(SMD)	6706C2502200	1	C15	신규
32	CONDENSER	470uF/25V(SMD)	6706C2504700	1	C24	신규
33	CONDENSER-CHIP	47uF/16V(Tantal)	6702CAP0106D	1	C12	신규
34	CONDENSER-CHIP	CL21F 104KBNC	6712CHP01040	7	C1,11,13,16,25,26,28	
35	CONNECTOR(WAFER)	LWL0640-03 (LSW250-03)	7802CLL00030	1	CN3	
36	CONNECTOR(WAFER)	LWL0640-02 (LSW250-02)	7802CLL00020	1	CN4(PB)	
37	CONNECTOR(WAFER)	02-5267	7805CCN67020	1	CN5(DRY)	
38	FUSE	1.6A/250V ø5 UL,S,VDE,BSI(☹)fast blow type	7620S0516000	1	FUSE1	
39	FUSE HOLDER	GF-205B(EXP-300L)	7630S0002050	1	FUSE1	
40	PIEZO BUZZER	APR,ADR(CHINA)	7002Z0000000	1	BZ1	
41	JUMP WIRE	ø0.6*10m/m	7844W0001000	1		
42	JUMPER	2PIN	7821CJM00020	3	JP1,+5V,BAT	
43	LCD	2402TF-P,B1(DB-II,DBB,NT)YEBC	7212D000010B	1	LCD1	신규
44	DIODE-TVS	SD05	6294ICP00050	2	D11,12	
45	TACT S/W	11902(DJTA-1102)	7600STA19020	1	S5	
46	TACT S/W	KPT-1105B(DJTA-1102C)	7600STA1105B	4	S1,2,3,4	
47	Modular Jack	RJ-11(6P), Straight	7810C000006A	1	CN2	
48	LED BACKLIGHT	PB-LCD(one module) = 자형,벽식	7224D0000031	1	BK1	신규

Service Manual – PB Series REV NO : 4

1.3 RS-232C PART(OPTION)

No	Part Name	Specification	Part Number	Q'ty	Remark	구분
1	CONDENSER-CHIP	CL21F 104KBNC	6712CHP01040	5	C3,4,5,6,7	OPTION
2	IC(INTERFACE)	SP3232ECY(3.3V)	6232IS032320	1	U2	OPTION

1.4 CHARGE PART(OPTION)

No	Part Name	Specification	Part Number	Q'ty	Remark	구분
1	RESISTOR 2W	CFR 0.33Ω (±5%)	6512CJ000033	1	R22	OPTION
2	CONDENSER-CHIP	CL21F 104KBNC	6712CHP01040	1	C18	OPTION
3	RESISTOR-CHIP 1/10W	RR1220P-103D(10KΩ)	6527ID301000	1	R24	OPTION
4	RESISTOR-CHIP 1/10W	RR1220P-202D(2KΩ)	6527ID300200	1	R25	OPTION
5	RESISTOR-CHIP 1/10W	RR1220P-470D(47Ω)	6527ID300047	1	R26	OPTION
6	IC(DC DC CONVERTER)	MC34063AD	6242I003406A	1	U6	OPTION
7	CONDENSER-CHIP	CL21F 471KBNC	6712CHP04710	1	C22	OPTION
8	INDUCTANCE	220uH(NT SERIES)	6670T0102200	1	L8	OPTION
9	CONDENSER-CHIP	470uF/25V(SMD)	6706C2504700	1	C23	신규OPTION
10	DIODE POWER	1N5819(SMD)	6291IS058190	3	D4, 5, 7	OPTION
11	RESISTOR-CHIP 1/10W	RR1220P-333D(33 Ω)	6527ID303300	1	R27	OPTION
12	RESISTOR-CHIP 1/10W	RR1220P-102D(1KΩ)	6527ID300100	1	R30	OPTION
13	RESISTOR-CHIP 1/10W	RR1220P-103D(10KΩ)	6527ID301000	1	R33	OPTION
14	RESISTOR-CHIP 1/10W	RR1220P-104D(100KΩ)	6527ID310000	2	R31,34	OPTION
15	RESISTOR-CHIP 1/10W	RR1220P-222D(2.2KΩ)	6527ID300220	2	R28,35	OPTION
17	IC(LINEAR)	LM393D(SOP)	6241IS003930	1	U9	OPTION
18	LED LAMP	ø5-(R,G) BL-BEG 204	7232DRG00050	1	D9	OPTION

1.6 DISPLAY ASS'Y(전자)

No	Part Number	Part Name	Specification	Q'ty	Remark	구분
1	CONNECTOR WIRE	3P*220*303(CORE)	7840W000303C	1		신규
2	BATTERY WIRE	2P*70/190mm(PB)	7840W0072190	1		신규
3	BATTERY HOLDER WIRE	0.18*12C*200MM(M(GRN,PB)	7870WGN02900	1		신규
4	CONNECTOR WIRE	2P*120/170mm(SW-LR BATTERY)	7840W000218A	1		OPTION
5	BATTERY	6V1.3AH_20HR(SW-LR)	7520-P00-0136	1		OPTION
6	CUSHION-VFD	30*20*2T	2631A0000010	2		

1.7 C/T BOX ASS'Y (전자)

No	Part Number	Part Name	Specification	Q'ty	Remark	구분
1	DRY BATTERY	Manganese(C Type)	7520P0000400	4		
2	RS-232C WIRE	D9P*6P PHONE JACK-2M	7840W0009060	1		신규OPTION
3	SMPS ADAPTOR	100-240V / 12V 1.25A	7562-P12-02CE	1		OPTION

NO	CAUSE	DATE	APPROVAL	
4	PCB Artwork, Part List, Calibration Setting , Options Installing Revison	2010.02.09	Kim kwanghyun	